

AXOLUTE AIR ASSEMBLY

Boxes

Supporting frames

No. of modules

Cover plates

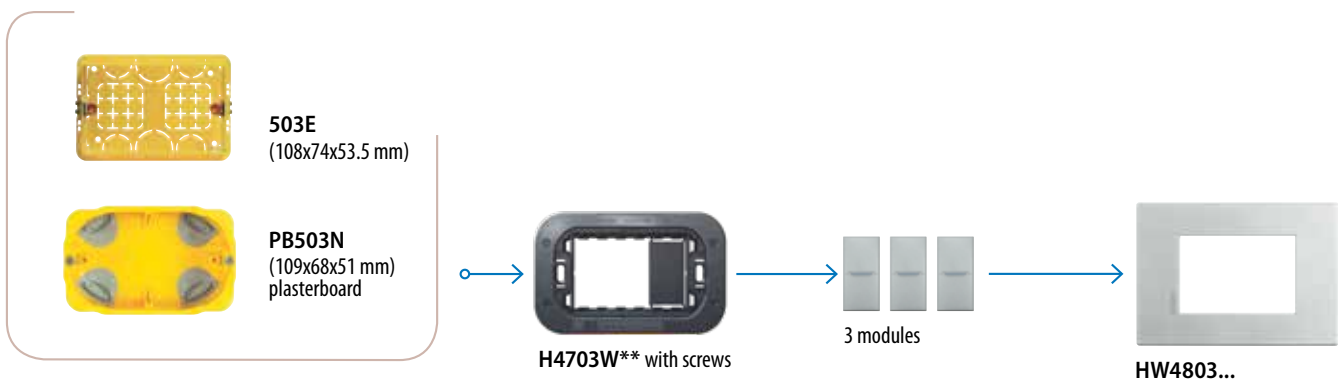

** Backing with knock-outs: to be removed if 3 modules are installed.

Boxes

Supporting frames

No. of modules

Cover plates

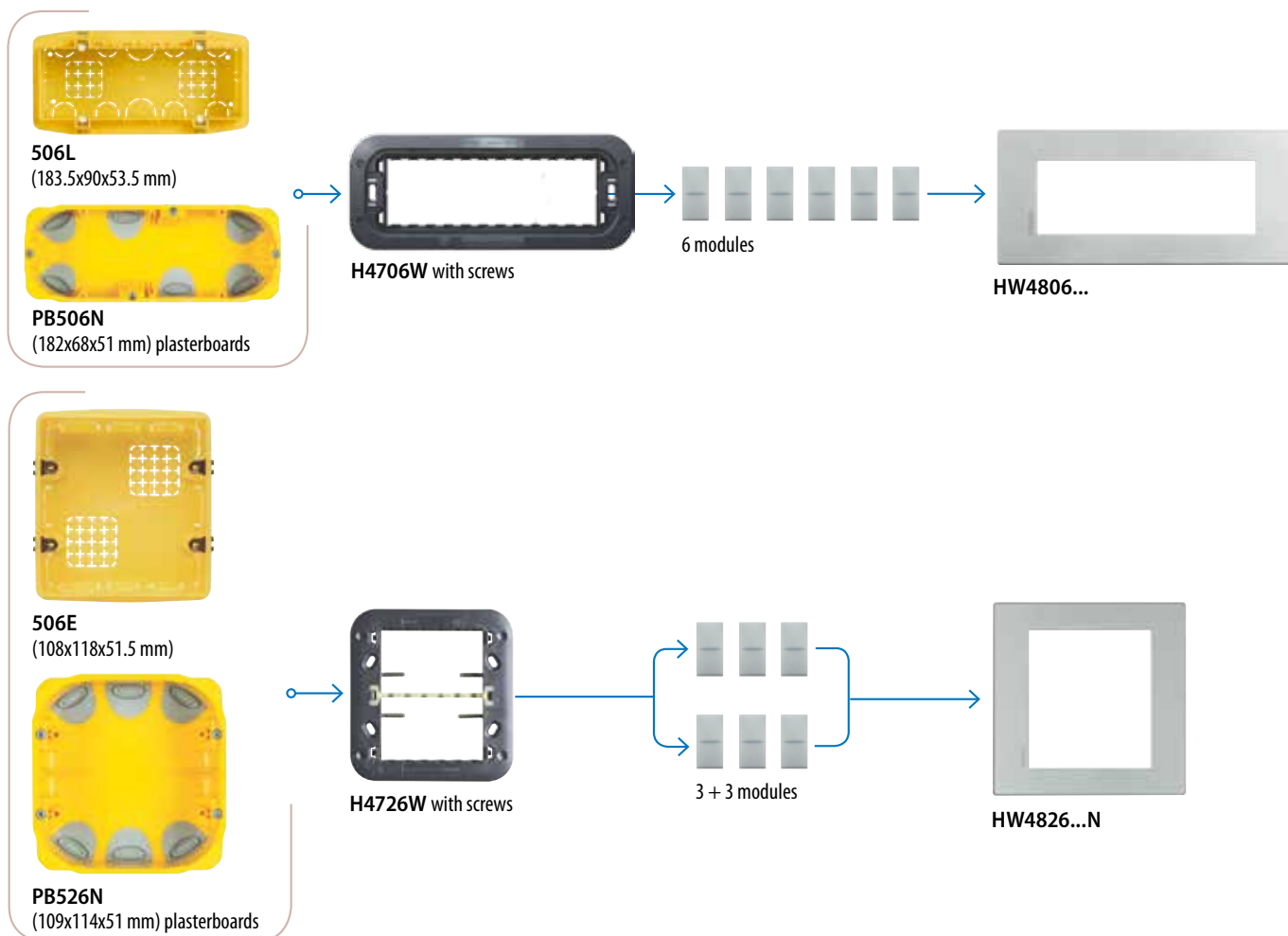

TABLE FOR SELECTING CODES

Modules

		2	3	4	6	3+3
MONOCHROME						
	White Axolute	HW4819HD	HW4803HD	HW4804HD	HW4806HD	HW4826HDN
	Tech	HW4819HC	HW4803HC	HW4804HC	HW4806HC	HW4826HCN
	Anthracite	HW4819HS	HW4803HS	HW4804HS	HW4806HS	HW4826HSN
BRUSHED						
	Brushed Titanium	HW4819CRS	HW4803CRS	HW4804CRS	HW4806CRS	HW4826CRS
	Brushed chrome	HW4819TIS	HW4803TIS	HW4804TIS	HW4806TIS	HW4826TIS
SOFT						
	Matt white	HW4819AW	HW4803AW	HW4804AW	HW4806AW	HW4826AWN
	Sand	HW4819SB	HW4803SB	HW4803SB	HW4803SB	HW4803SB
	Eclipse	HW4819XN	HW4803XN	HW4803XN	HW4803XN	HW4803XN

Supporting frames

with screws	H4703W	H4703W	H4704W	H4706W	H4726W
-------------	--------	--------	--------	--------	--------

Note: contact the BTicino sales technicians for the installation of MyHOME 3.5 screen and Videodisplay

COVER PLATES

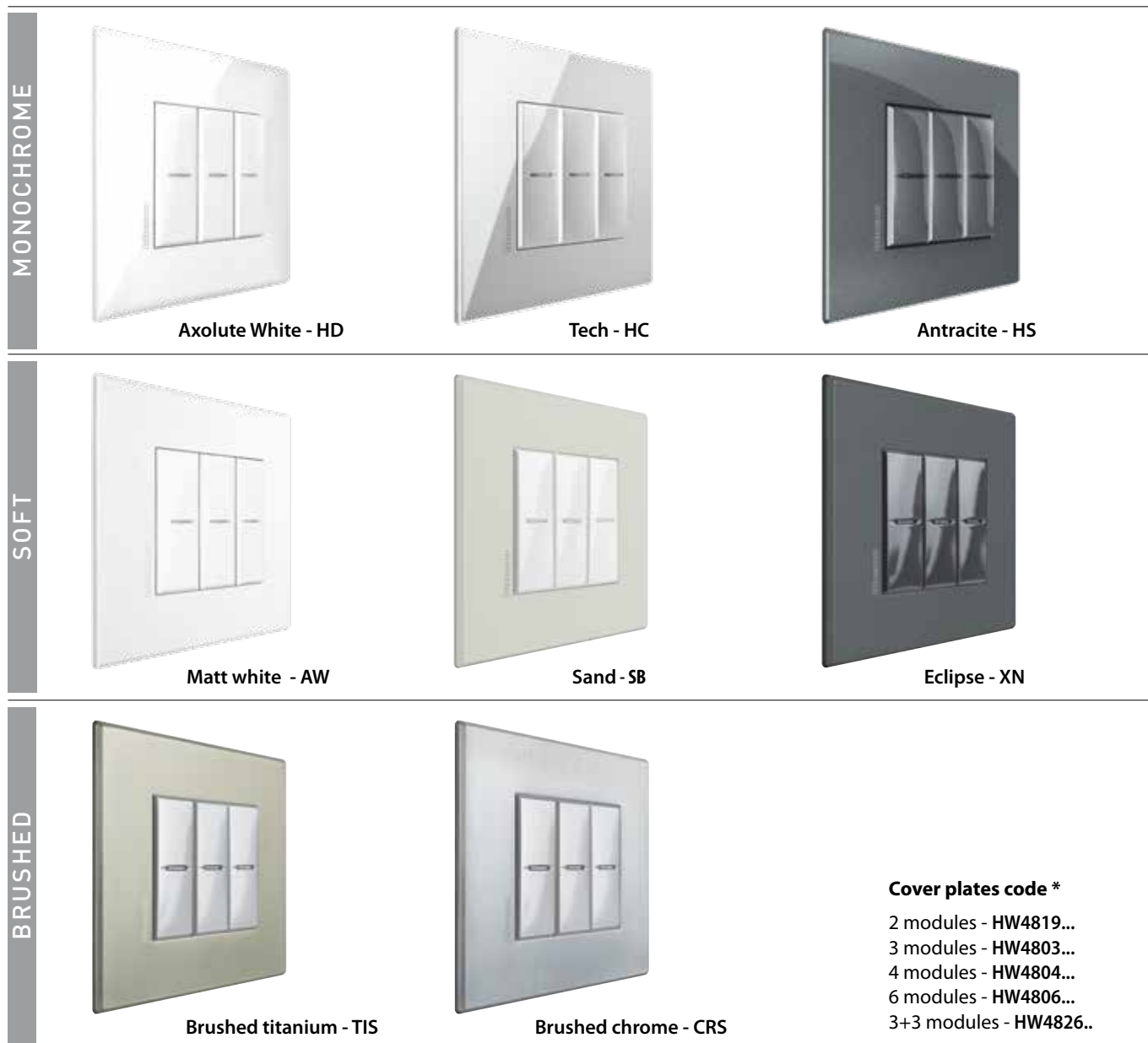

Cover plates code *
 2 modules - HW4819...
 3 modules - HW4803...
 4 modules - HW4804...
 6 modules - HW4806...
 3+3 modules - HW4826..

Matt white cover plate that can be painted



Before painting the matt white - AW cover plate



After Painting The Cover Plate

SUGGESTIONS FOR USE

The MATT WHITE cover plate can also be painted.

PAINTING

The matt white paint of the cover plates - **AW** - can be used as a primer. Before painting with house paint, the surface should be sanded/matted for better adhesion. Resin-rich products (e.g. water-based varnishes) should be used.

Notes

- Do not paint the devices (keys, sockets, etc.)
- Paint the cover plate separately and mount it when it is dry

CLEANING THE COVER PLATE

Water-based detergents should be used. Using ethyl alcohol or other solvents which could damage or soften the paint is not recommended.



Art. H4802KY

Note: Use the tool with suction cups item H4892KY to remove the installed cover plates

* see Axolute AIR assembly page for details

DIMENSIONAL DATA

Axolute AIR cover plates and support frames

AXOLUTE AIR COVER PLATES

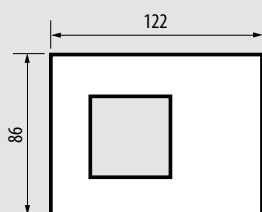

HW4802...

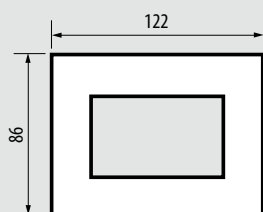

HW4803...

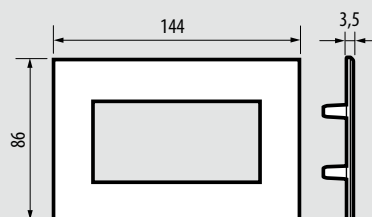

HW4804...

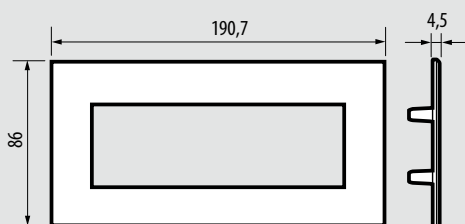

HW4806...

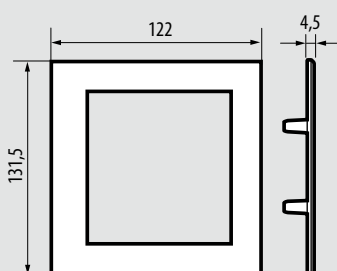

HW4826...

AXOLUTE AIR SUPPORT FRAMES

2 AND 3 MODULES

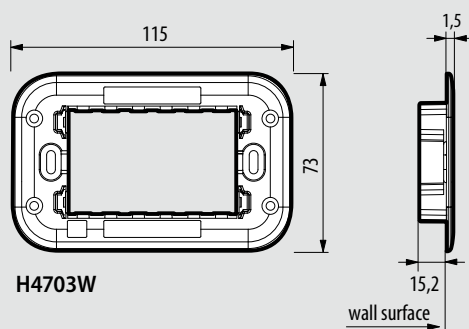

H4703W

4 MODULES

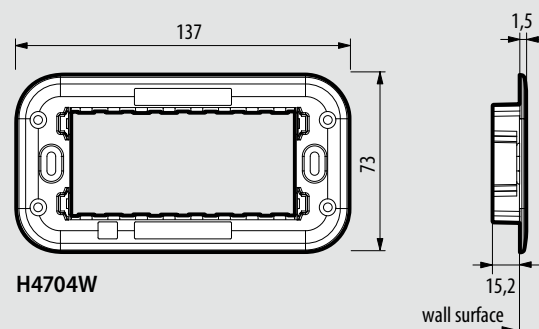

H4704W

6 MODULES

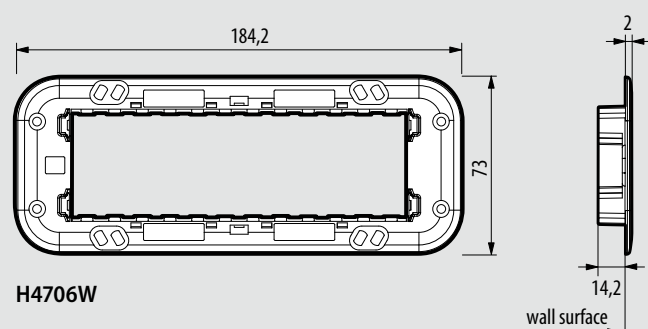

H4706W

3+3 MODULES

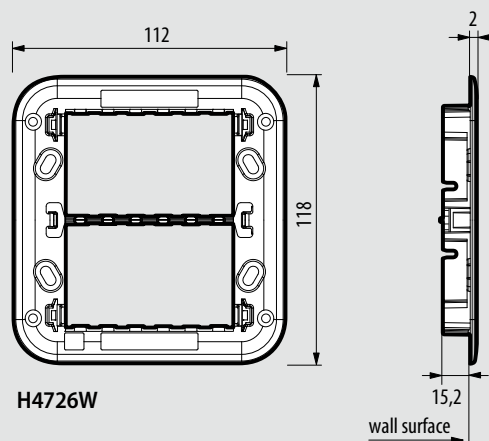

H4726W

LIVINGLIGHT AIR - 2 MODULE AREA INSTALLATION SYSTEM

Cover plate installation

Boxes

Supports

No. of modules

Cover plates

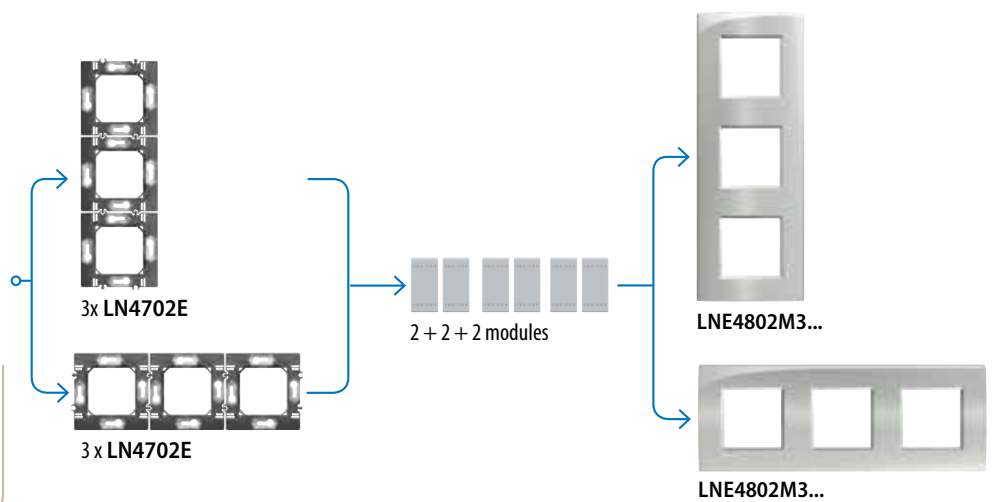
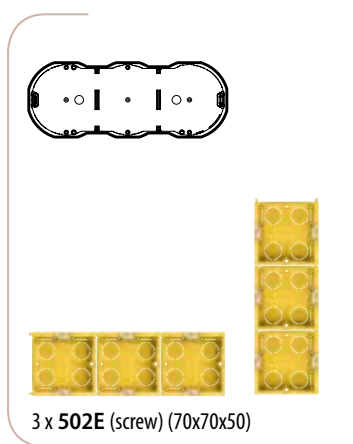
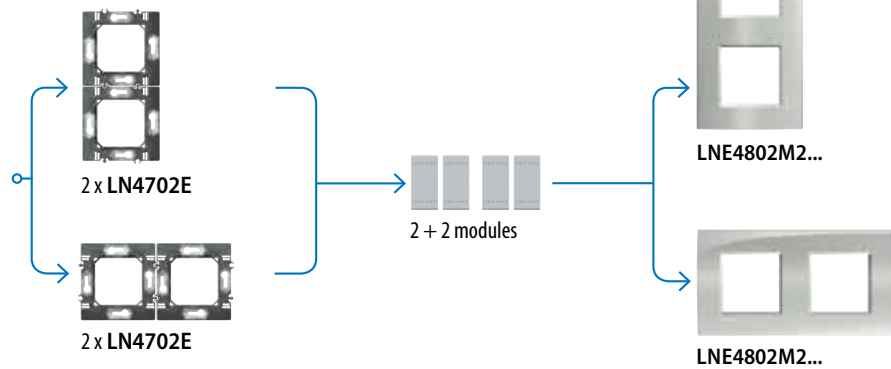
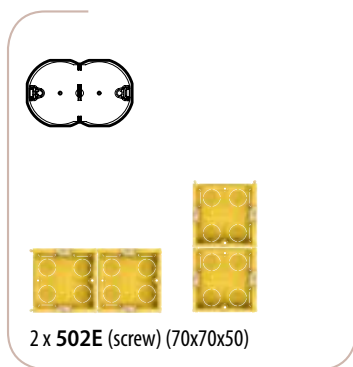
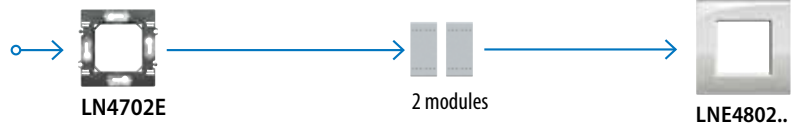

Note: 40 mm dept boxes for flexible cables installations
50 mm dept boxes for rigid cables installations
PB502A = accessory for side by side installation of 502PB boxes

Note: The clear protection is supplied as standard with Air supports, to preserve the integrity of the devices, protecting them from installation dust, paint and scratches during all stages after their installation, and until the cover plates are fitted.

LIVINGLIGHT AIR

Cover plate finishing

MONOCHROME

Materiál: zámak



Pure white - BN



Tech - TE



Anthracite - AR

SOFT

Materiál: zámak



Street - ST



Clay - CY



Sand - SB



Blue moon - BM

BRUSHED

Materiál: zámak



Brushed Titanium - TIS



Brushed Chrome - CRS

LIVINGLIGHT AIR

Cover plate finishing



Cover plates: table for selecting codes

AIR COVER PLATE CODES

2 modules - LNE4802...

2 + 2 modules - LNE4802M2...

2 + 2 + 2 modules - LNE4802M3...

Cover plate modules

	2	2+2	2+2+2	
MONOCHROME (zamak)				
	Pure white	LNE4802BN	LNE4802M2BN	LNE4802M3BN
	Tech	LNE4802TE	LNE4802M2TE	LNE4802M3TE
	Anthracite	LNE480AR	LNE4802M2AR	LNE4802M3AR
SOFT (zamak)				
	Street	LNC4802ST	LNE4802M2ST	LNE4802M3ST
	Clay	LNC4802CY	LNE4802M2CY	LNE4802M3CY
	Sand	LNC4802SB	LNE4802M2SB	LNE4802M3SB
	Blue moon	LNC4802BM	LNE4802M2BM	LNE4802M3BM
SHINY (zamak)				
	Pewter	LNC4802PT	LNE4802M2PT	LNE4802M3PT
	Palladium	LNC4802PL	LNE4802M2PL	LNE4802M3PL
	Satin gold	LNC4802OF	LNE4802M2OF	LNE4802M3OF
	Satin nickel	LNC4802NK	LNE4802M2NK	LNE4802M3NK
	Pearl white	LNC4802PR	LNE4802M2PR	LNE4802M3PR
BRUSHED (zamak)				
	Brushed titanium	LNC4802TIS	LNE4802M2TIS	LNE4802M3TIS
	brushed chrome	LNC4802CRS	LNE4802M2CRS	LNE4802M3CRS

Supports

Supports	LN4702E	LN4702E x 2	LN4702E x 3
----------	---------	-------------	-------------

LIVINGLIGHT AIR - 3 MODULE AREA INSTALLATION SYSTEM

Cover plate installation

Boxes

Supports

No. of modules

AIR cover plates

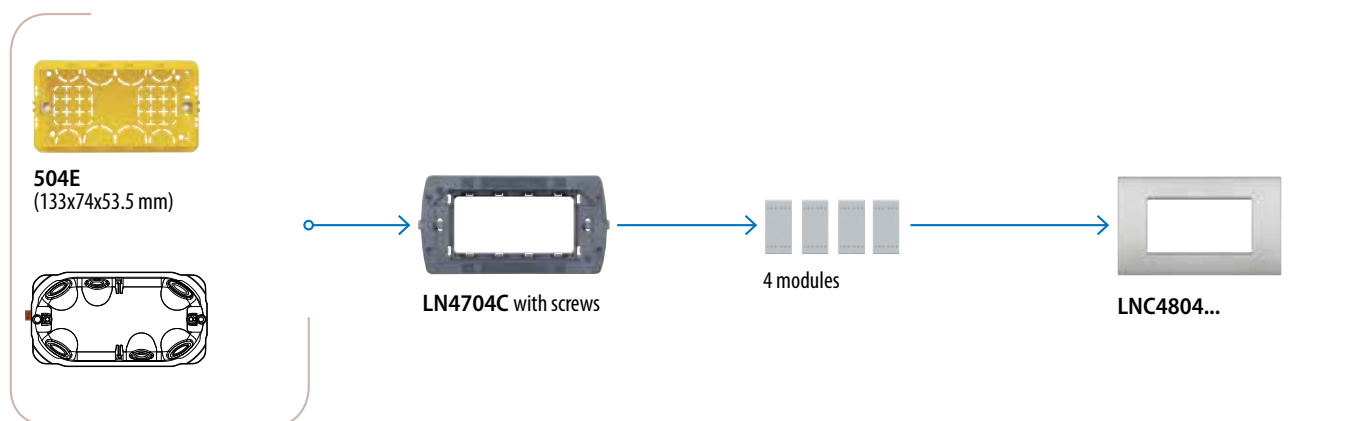
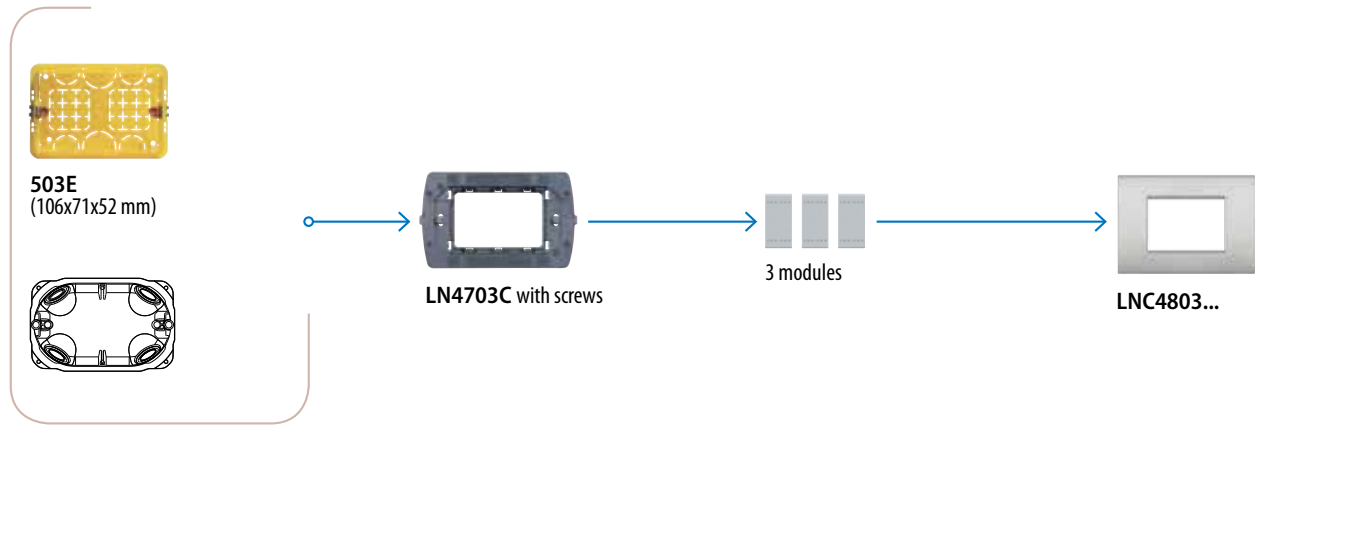

Note: The clear protection is supplied **as standard with Air supports**, to preserve the integrity of the devices, protecting them from installation dust, paint and scratches during all stages after their installation, and until the cover plates are fitted.

Boxes

Supports

No. of modules

AIR cover plates

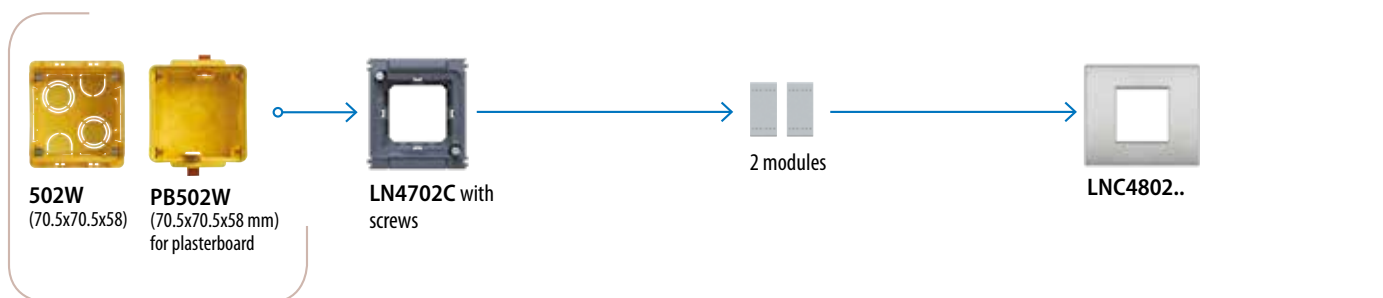
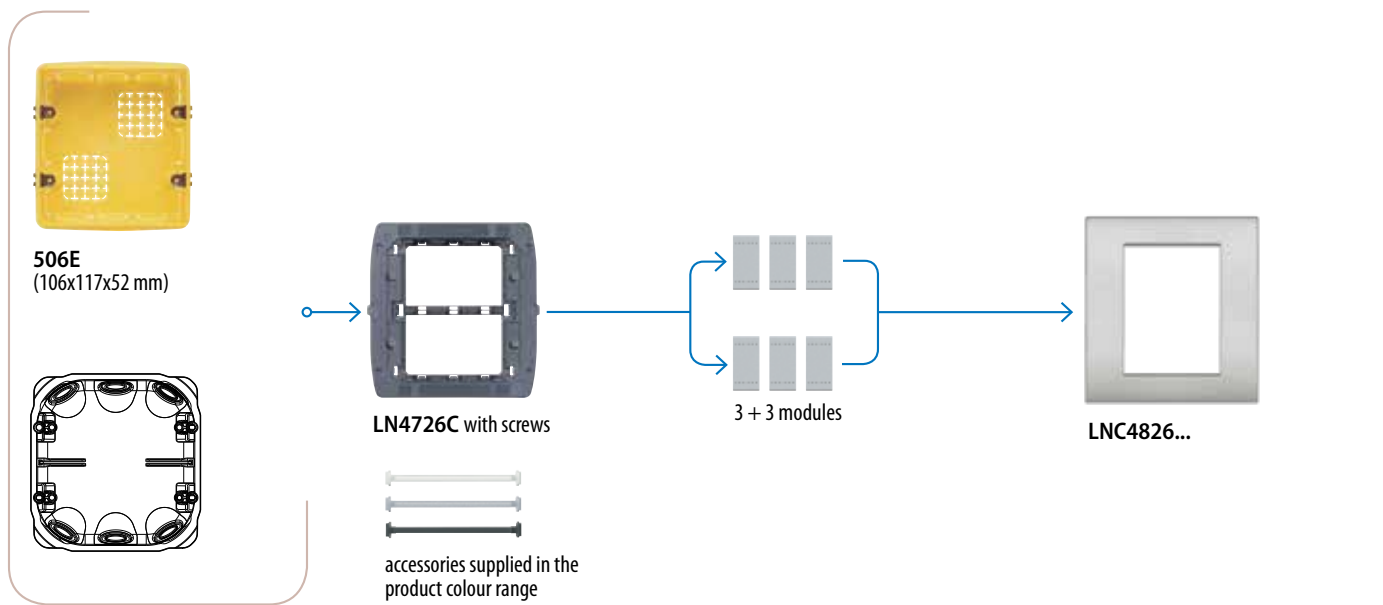
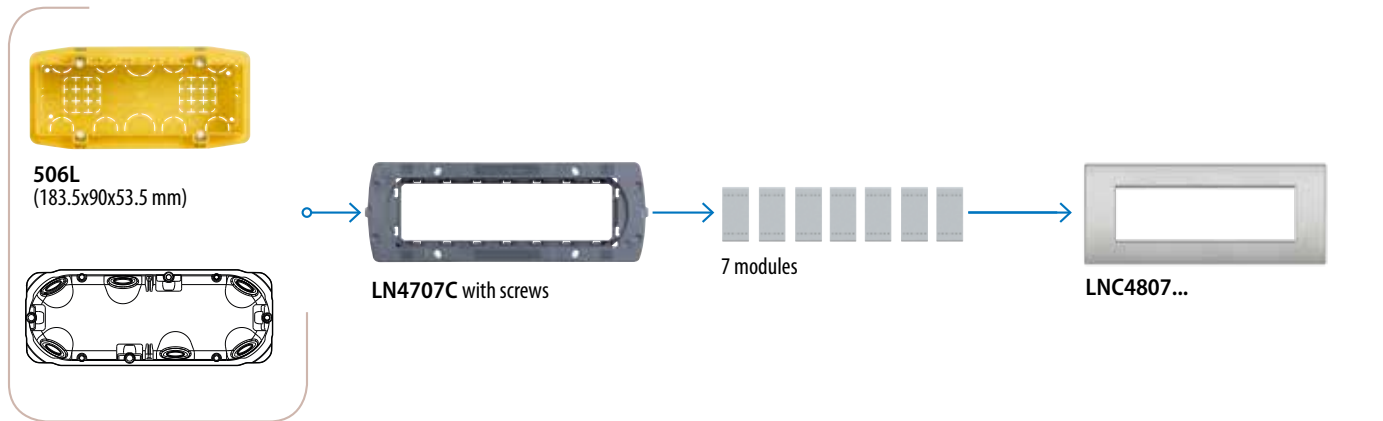

LIVINGLIGHT AIR - 3 MODULE AREA INSTALLATION SYSTEM

Cover plate colours

MONOCHROME

Material: zamak



Pure white - BN



Tech - TE



Anthracite - AR

SOFT

Material: zamak



Street - ST



Clay - CY



Sand - SB



Blue moon - BM

AIR COVER PLATE CODES

2 modules - LNC4802...

3 modules - LNC4803...

4 modules - LNC4804...

7 modules - LNC4807...

3+3 modules - LNC4826...

BRUSHED
Material: zamak



Brushed Titanium - TIS



Brushed Chrome - CRS

SHINY
Material: zamak



Pewter - PT



Palladium - PL



Satin gold - OF



Satin nickel - NK

















Pearl white - PR

LIVINGLIGHT AIR

Selection table for cover plate codes

Cover plate modules

		3	4	7	3+3
MONOCHROME (zamak)					
	Pure white	LNC4803BN	LNC4804BN	LNC4807BN	LNC4826BN
	Tech	LNC4803TE	LNC4804TE	LNC4807TE	LNC4826TE
	Anthracite	LNC4803AR	LNC4804AR	LNC4807AR	LNC4826AR
SOFT (zamak)					
	Street	LNC4803ST	LNC4804ST	LNC4807ST	LNC4826ST
	Clay	LNC4803CY	LNC4804CY	LNC4807CY	LNC4826CY
	Sand	LNC4803SB	LNC4804SB	LNC4807SB	LNC4826SB
	Blue moon	LNC4803BM	LNC4804BM	LNC4807BM	LNC4826BM
SHINY (zamak)					
	Pewter	LNC4803PT	LNC4804PT	LNC4807PT	LNC4826PT
	Palladium	LNC4803PL	LNC4804PL	LNC4807PL	LNC4826PL
	Satin gold	LNC4803OF	LNC4804OF	LNC4807OF	LNC4826OF
	Satin nickel	LNC4803NK	LNC4804NK	LNC4807NK	LNC4826NK
	Pearl white	LNC4803PR	LNC4804PR	LNC4807PR	LNC4826PR
BRUSHED (zamak)					
	Brushed titanium	LNC4803TIS	LNC4804TIS	LNC4807TIS	LNC4826TIS
	Brushed chrome	LNC4803CRS	LNC4804CRS	LNC4807CRS	LNC4826CRS

Supports

Supports	LN4703C	LN4704C	LN4707C	LN4726C
-----------------	---------	---------	---------	---------

DIMENSIONAL DATA

LIVINGLIGHT AIR cover plates

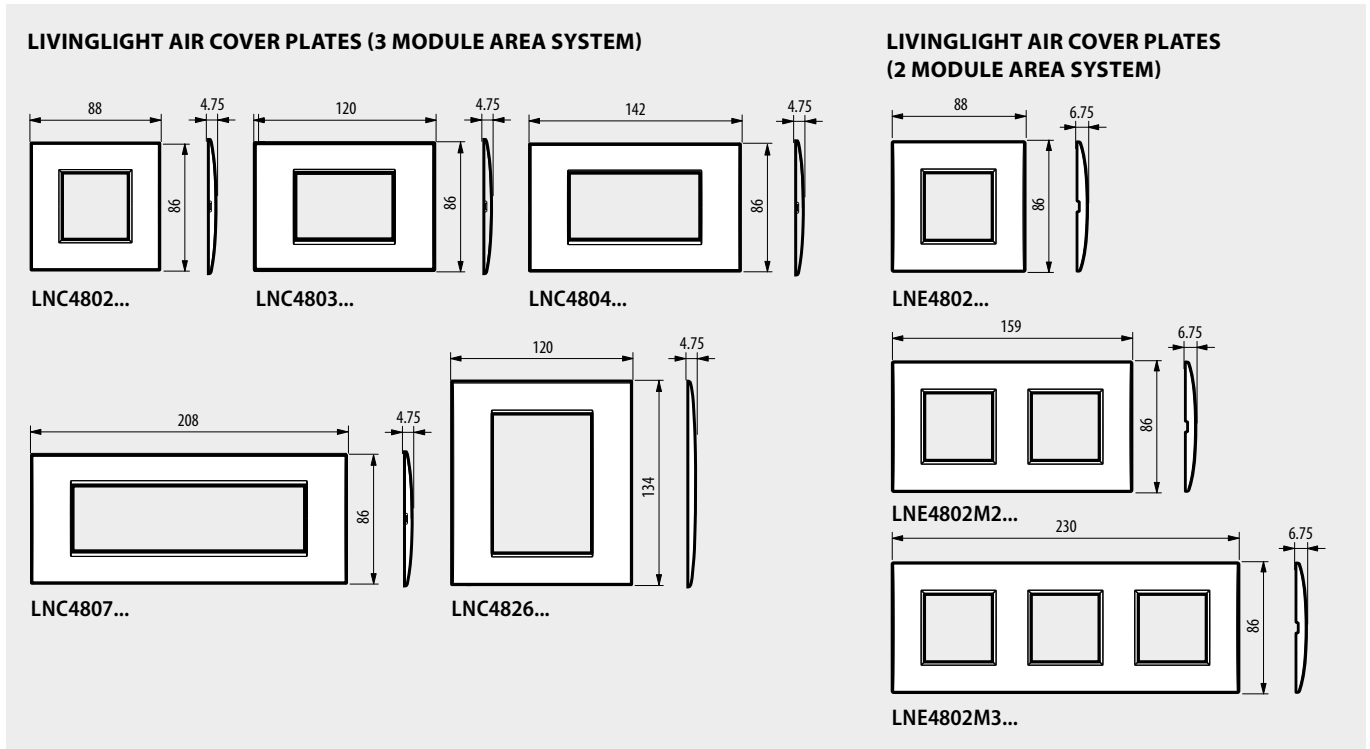

Box and cover plates for rails

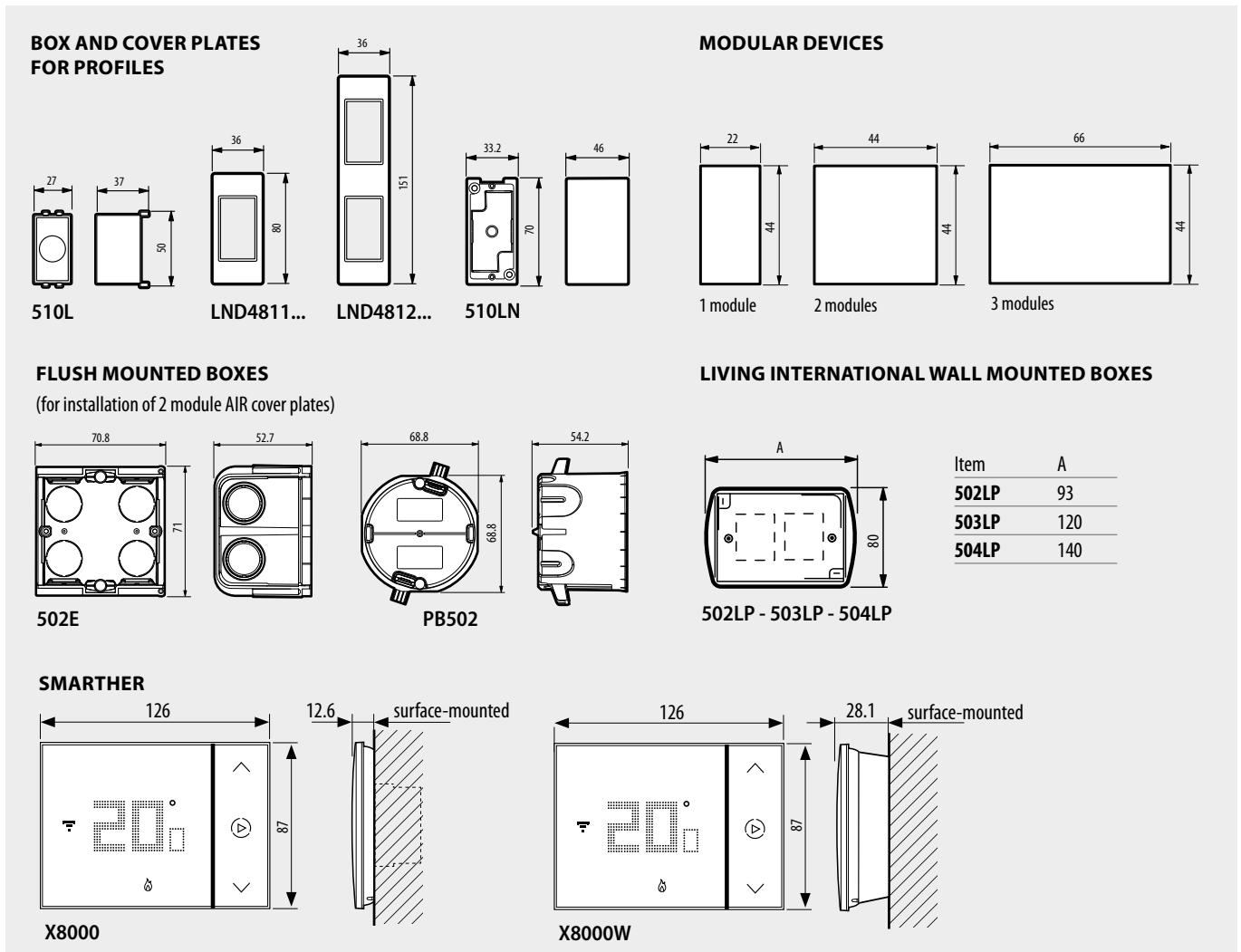

DIMENSIONAL DATA

Livinglight AIR supports

Livinglight / Living International supports

3-MODULE SUPPORT

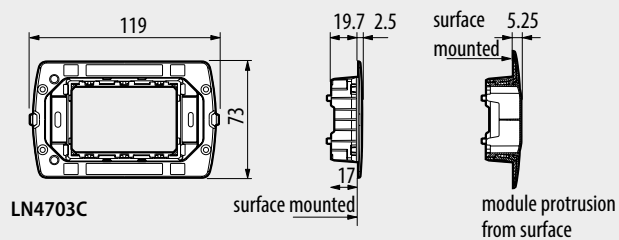

4-MODULE SUPPORT

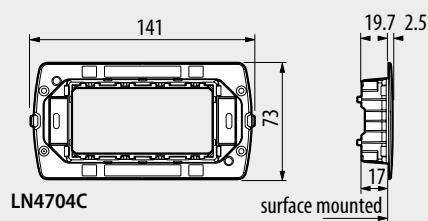

7-MODULE SUPPORT

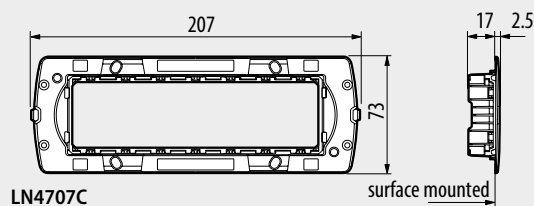

3+3-MODULE SUPPORT

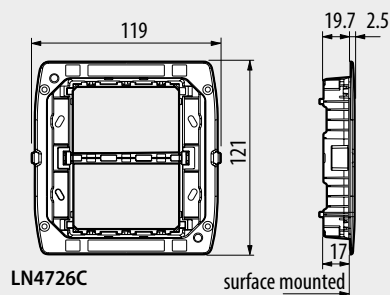

2-MODULE SUPPORT

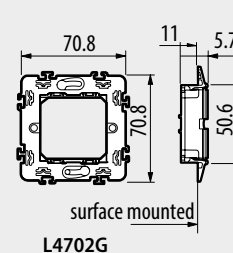
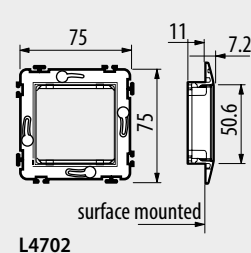
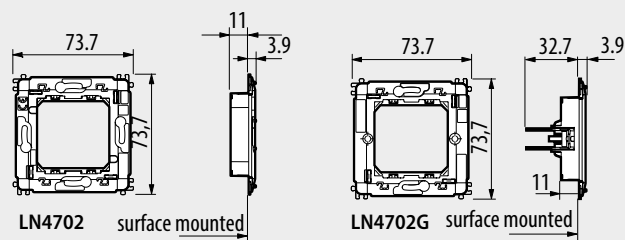

3-MODULE SUPPORT

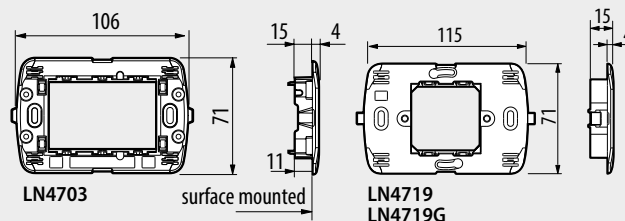

4-MODULE SUPPORT

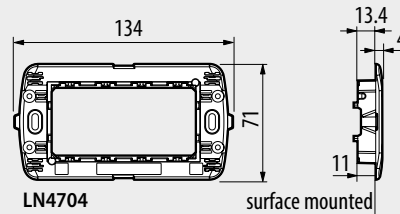

7-MODULE SUPPORT

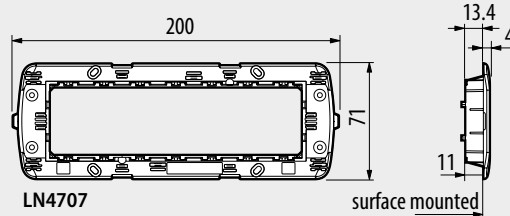

3+3-MODULE SUPPORT

